

SCREENLINE.IT

Driven to the future



Electric screens

TRIM
SLIM

MOT
LODOVICO

LODOVICO NO BOX
NEW BIGMOT CINEMASCOPE

Frame screens

FASHION
FASHION RETROLIGHT

FASHION VELVET WIDE
BIG FRAME

Rental screens

MULTIFRAME

Manual screens

NEW CONVENTION
ECOSPRINGROLL

ECOTRIPOD
WALL DELUXX

TRIPOD DELUXX

Top line

GRAND CINEMA TENSIONED
INCEILING SCREEN
INCEILING TENSIONED

BRILLIANT
ART SCREEN
COPERNICO

COPERNICO INCEILING
KEPLERO
KEPLERO INCEILING

Accessories and Fabrics

ACCESSORIES

FABRICS

Electric screens

Frame screens

Rental screens

Manual screens

Top line

Accessories and Fabrics



Trim

Entry level motorized screen

The oval shape and the small encumbrance make it pleasantly suitable to any kind of application. Keen price by keeping the high quality in components and manufacturing

Trim screen is the perfect solution for all public tenders, huge installations where is necessary to match a keen price with a made in Italy product. It's available in 3 different sizes with white ice fabric. The lateral black masking can be requested on 4:3 and 16:9 screens.

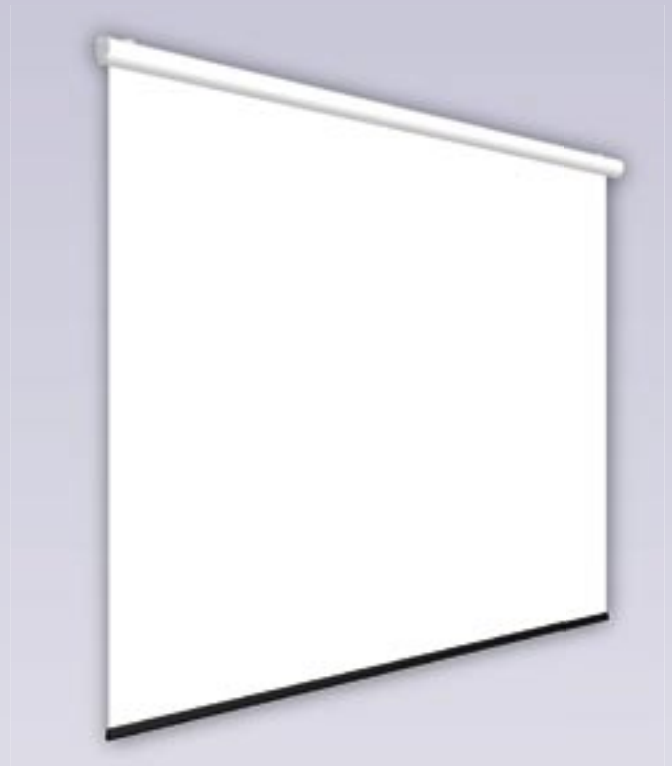

Close-up of the wall or ceiling bracket.

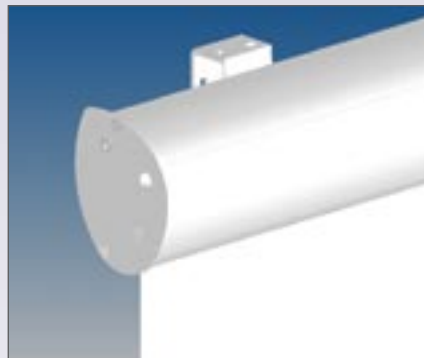

Close-up view of a mounted screen.

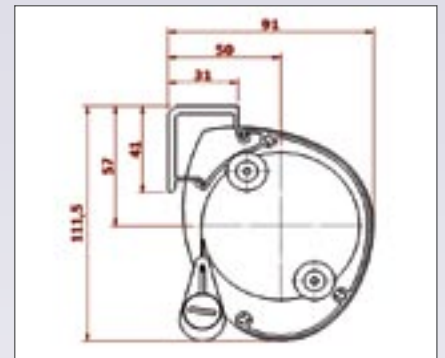

Dimensions of the lateral section of the screen.

Size-chart

Mod	4:3		20 cm drop 4:3		50 cm drop 16:9		1:1		L (cm)	KG
	B x H (cm)	D	B x H (cm)	D	B x H (cm)	D	B x H (cm)	D		
180	180 x 135	088"	170 x 127	084"	170 x 96	077"	180 x 180	100"	188	10
210	210 x 160	104"	200 x 150	098"	200 x 112	090"	210 x 210	117"	218	12
250	250 x 190	124"	240 x 180	118"	240 x 135	108"	250 x 250	139"	258	14

Features

- available ex stock
- small encumbrance
- Quick & Safe mounting system

Available surfaces

- white ice

Slim

The most famous among all ScreenLine's electrical models. Available up to 250 cm base in a smooth elegant box with rounded angles. Thanks to the white dull finishing and the neutral aesthetic It is ideal in any environment especially in livingrooms, small and medium sized conference-rooms.

The box is improved in elegance by the coordinated white lateral plates that hide all screws.

PVC surfaces available both for front and rear projection, can be customized according to any special request: with black masking or white surface. The improved new generation motor combined to the ultimate technology in manufacturing makes this screen extremely noiseless.

The special brackets can be fixed on the wall, on the ceiling and on any kind of wooden beam.

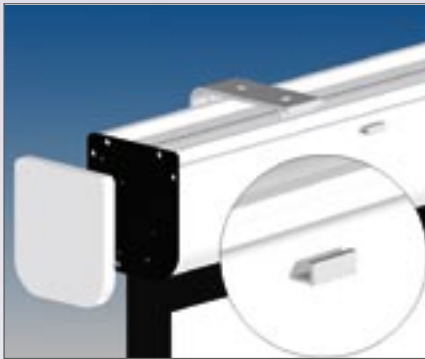

Quick & Safe system. Close-up view of components.

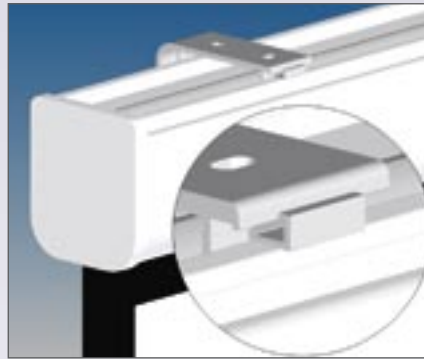

Mounted and secured screen. The bracket may be fastened behind, on top or in front of the case.

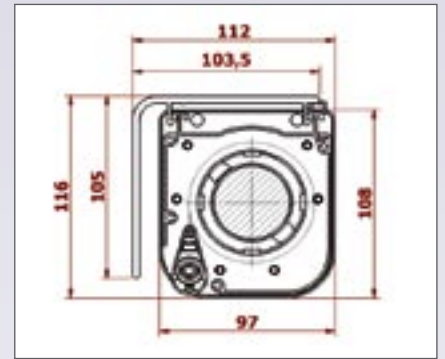

Dimensions of the lateral section of the screen.

Size-chart

Mod	4:3		20 cm drop 4:3		50 cm drop 16:9		1:1		L (cm)	KG
	B x H (cm)	D	B x H (cm)	D	B x H (cm)	D	B x H (cm)	D		
160	160 x 120	079"	150 x 112	074"	150 x 85	068"	160 x 160	089"	168	12
180	180 x 135	088"	170 x 127	084"	170 x 95	077"	180 x 180	100"	188	15
200	200 x 150	098"	190 x 142	093"	190 x 106	086"	200 x 200	111"	208	17
250	250 x 190	124"	240 x 180	118"	240 x 135	108"	250 x 250	139"	258	21

Features

- 100% Aluminium box
- extremely noiseless motor
- large variety of available fabrics and sizes
- coordinated side plates
- Quick & Safe mounting system
- customizable on request

Available surfaces

- white ice
- home vision
- coral

Mot

The medium sized screen.

Thanks to the white dull medium-sized box and the neutral aesthetic, it can be easily installed in standard and large rooms. This model is supplied in a wide range of fabrics both for front and rear projection. All surfaces are available with a complimentary black masking in any proposed and customized measures. It is extremely silent thanks to the new generation motors and the noise-absorbing system.

Two coordinated lateral plates and electrical devices for the connection are available in any mounting kit.

Thanks to the exclusive Quick & Safe mounting system it can be easily installed on walls, ceiling and on any kind of wooden beam.

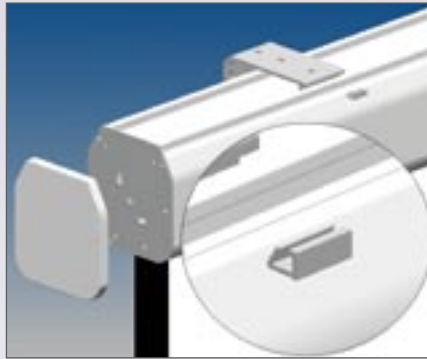

Quick & Safe system. Close-up view of the components.

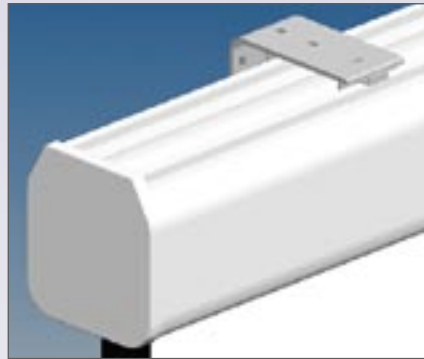

Mounted and secured screen. The bracket may be fastened behind, on top or in front of the case.

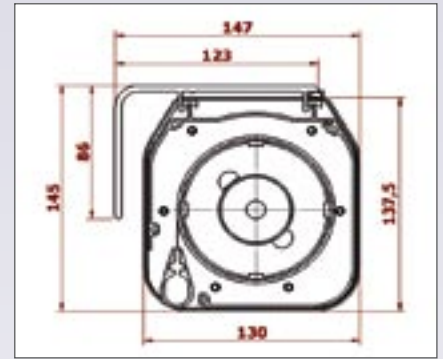

Dimensions of the lateral section of the screen.

Size-chart

Mod	4:3		20 cm drop 4:3		50 cm drop 16:9		1:1		L (cm)	KG
	B x H (cm)	D	B x H (cm)	D	B x H (cm)	D	B x H (cm)	D		
300	300 x 225	148"	290 x 217	143"	290 x 163	131"	300 x 300	167"	310	28
350	350 x 263	172"	340 x 255	167"	340 x 191	154"	350 x 350	195"	360	35
400	400 x 300	197"	390 x 292	192"	390 x 219	179"	400 x 400	223"	410	42

Features

- 100% Aluminium box
- extremely noiseless motor
- large variety of available fabrics and sizes
- coordinated side plates
- Quick & Safe mounting system
- customizable on request

Available surfaces

- white ice
- home vision
- coral

Lodovico

The huge sized professional screen.
 It has a strong aluminium structure with an elegant design and finishing of white dull varnish.
 Any kind of applications can be done thanks both to its regular L-shaped brackets that optionally can be spacing ones.
 The screen has been supplied with safety chains that allows an upper-grade of safety, once the screen is correctly anchored.
 Its device allows the screen to be manually operated while you have a black out. A wide choice of sizes and format are available together with several fabrics: front, rear and sound transparent with or without black masking.
 The cardboard box is strong thanks to lateral metal fastening.

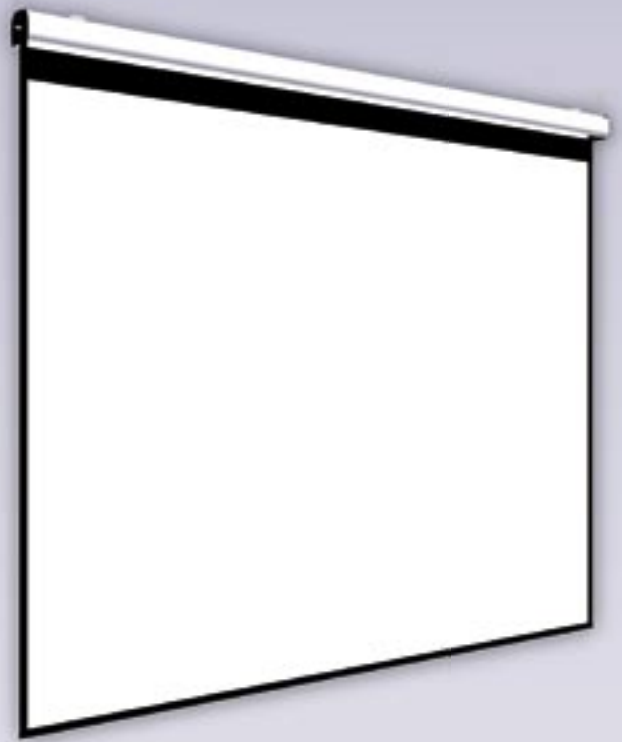

Quick & Safe system. View of the mounted front bracket.



View of the mounted back part. The chain is used both to move easily the screen and to secure it to two more points on the wall.

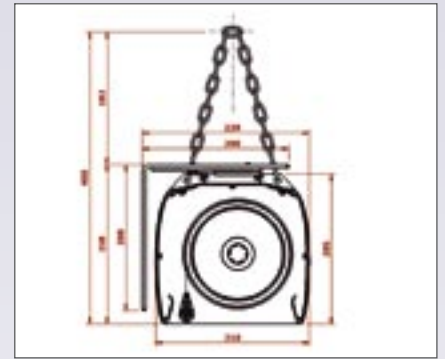

Dimensions of the lateral section of the screen.

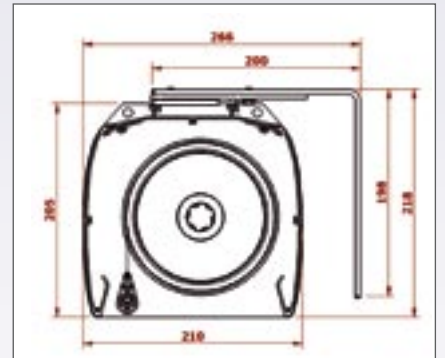
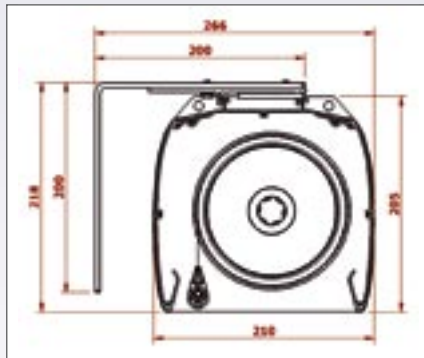
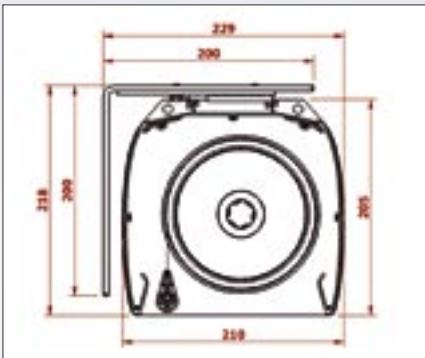

Lodovico/Lodovico no box Size-chart

Mod	4:3		20 cm drop 4:3		50 cm drop 16:9		1:1		L (cm)	KG
	B x H (cm)	D	B x H (cm)	D	B x H (cm)	D	B x H (cm)	D		
450	450 x 337	221"	440 x 330	217"	440 x 247	199"	450 x 450	251"	475	100
500	500 x 375	246"	490 x 367	241"	490 x 275	221"	500 x 500	278"	525	111
550	550 x 412	271"	540 x 405	266"	540 x 303	244"	550 x 550	306"	575	115
600	600 x 450	295"	590 x 442	290"	590 x 332	266"			625	119
650	650 x 487	320"	640 x 480	315"	640 x 360	289"			675	123
700	700 x 525	344"	690 x 517	339"	690 x 388	312"			725	127

Lodovico no Box

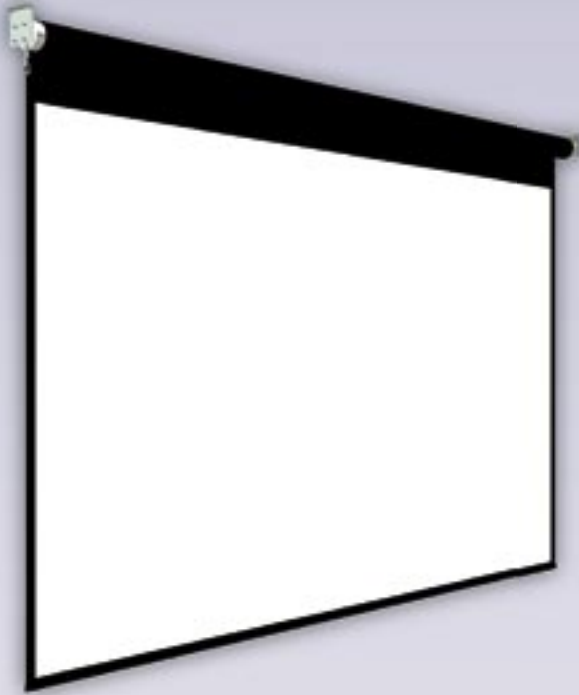

The big sized screen without box with a total aluminium and thick steel structure.

Thanks to the lateral brackets it can be hanged both on walls and ceilings. Special chains for a further anchor bolt in respecting TUV rules. It can be supplied with front, rear and soundtransparent fabrics. It's available with or without black masking. The packing has been reinforced with steel plates.



View of the box mounted on a support in front of the screen.



The emergency control is used in case of a power blackout.

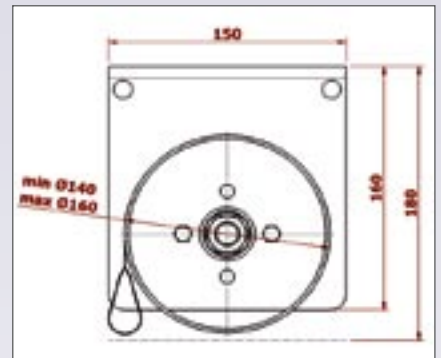

Dimensions of the lateral section of the screen.

Lodovico/Lodovico no box features

- 100% aluminium
- motor with an emergency manoeuvre
- safety chains
- customisation
- black masking as optional
- stronger packaging
- large variety of fabrics

Available surfaces

- white ice
- perforated
- home vision
- coral



New Bigmot Cinemascope

The huge screen dedicated to cinemas, theatres and multifunction halls.
 Totally redesigned in TUV rules respect, Bigmot Cinemascope is built by keeping the highest quality standards: double powered motors, and a double mechanical stop to avoid any accidental drop, the cable are housed by the special safety carter.

The running ends can be regulated through the staying at the ground level Installation requires only 2 people, few working hours thanks to the crank system that lift the box from the ground floor to the highest ceiling without any effort.

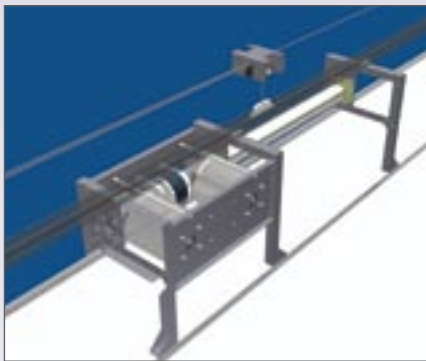

Motor: the action of the angle drives is reinforced by an electromechanical brake.

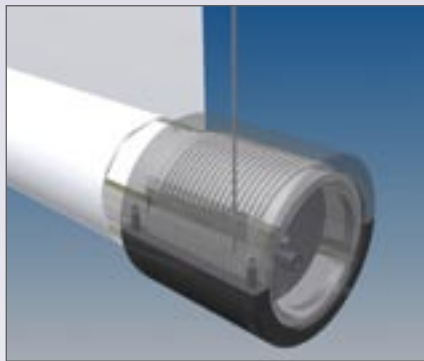

The rope guard staves off derailments from the pulleys and prevents extraneous objects from becoming entangled in the ropes.

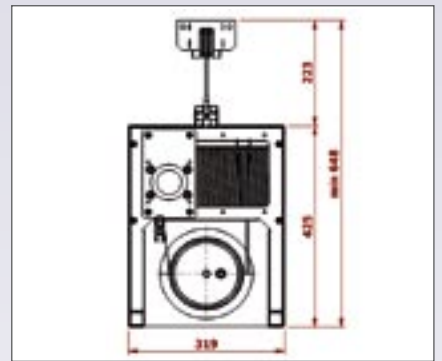

Dimensions of the lateral section of the screen and minimum space occupied by it.

Size-chart

Mod	B x H (cm)	D	X x Y x L (cm)	KG
800	800 x 440	359"	470 x 305 x 850	180
850	850 x 462	381"	470 x 305 x 900	190
900	900 x 483	402"	470 x 305 x 950	200
950	950 x 504	423"	470 x 305 x 1000	210
1000	1000 x 526	445"	470 x 305 x 1050	220
1050	1050 x 547	466"	470 x 305 x 1100	230
1100	1100 x 568	487"	470 x 305 x 1150	240
1150	1150 x 589	509"	470 x 305 x 1200	250
1200	1200 x 611	530"	470 x 305 x 1250	260

Features

- movement powered by steel cables
- central motor with stops adjustable from the floor
- additional mechanical top stops
- rope guards on rolling tube ends
- lifting system with manual winch
- lockable safety chain
- easier to lower, and thus to maintain, thanks to the winch

Available surfaces

- white ice
- perforated
- coral

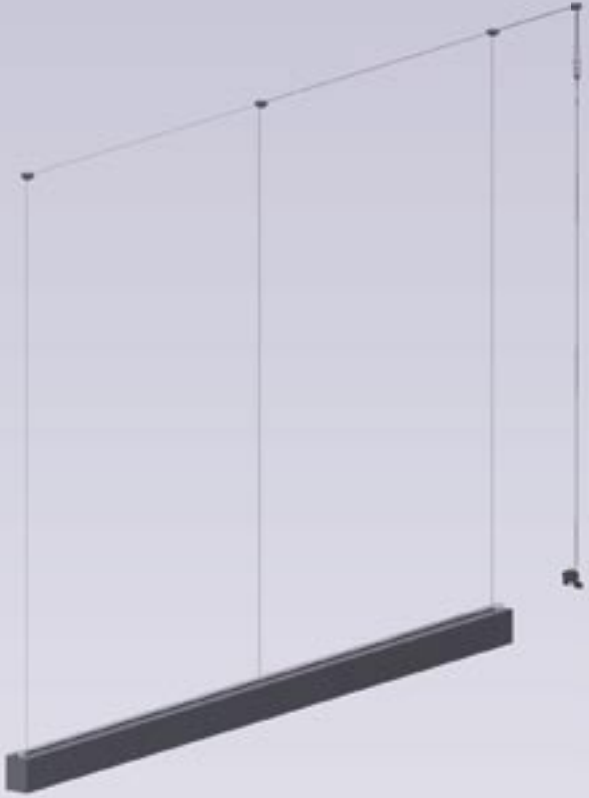

The new big screen system whose ScreenLine project has recently finalized, allows a very easy and safe installation. It takes less time, two technicians and a platform with wheels in order to mount the pulley into the ceiling.

After installing the winch to the wall, you start mounting the pulley in turn, 3 pulleys in the ceiling and 1 or more to overtake any kind of barrier/obstacle when the installation needs it.

The tightropes coming from the winch are anchored to the hooks that are positioned behind it.

By winching up you lift the screen at the definitive position, The safety cord avoids any possibility to prevent any careless action by unauthorized crew. On the other hand the same system safely and easily allows to pull the screen down to the floor to inspect it or repair it by avoiding any scaffolding and ladder.

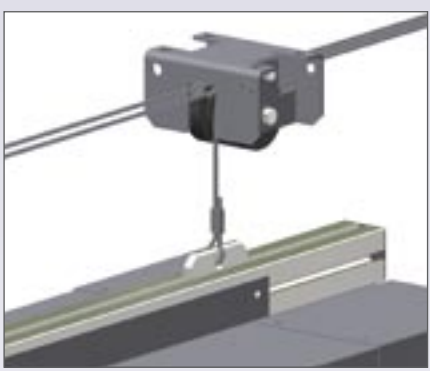

View of how the ropes are attached to the screen. The fastening block can be moved along the back beam.

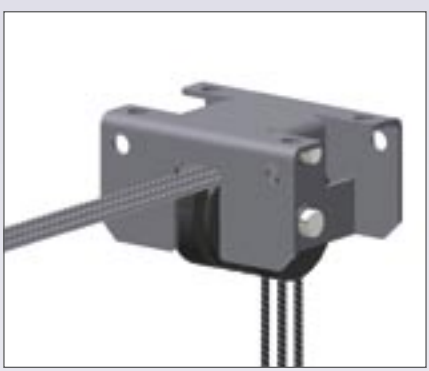

Angle drive for the ropes. Recurring to more pulleys means avoiding complex structures and hiding the winch.



The winch features a safety cord and three tensioners that adjust the screen horizontally.

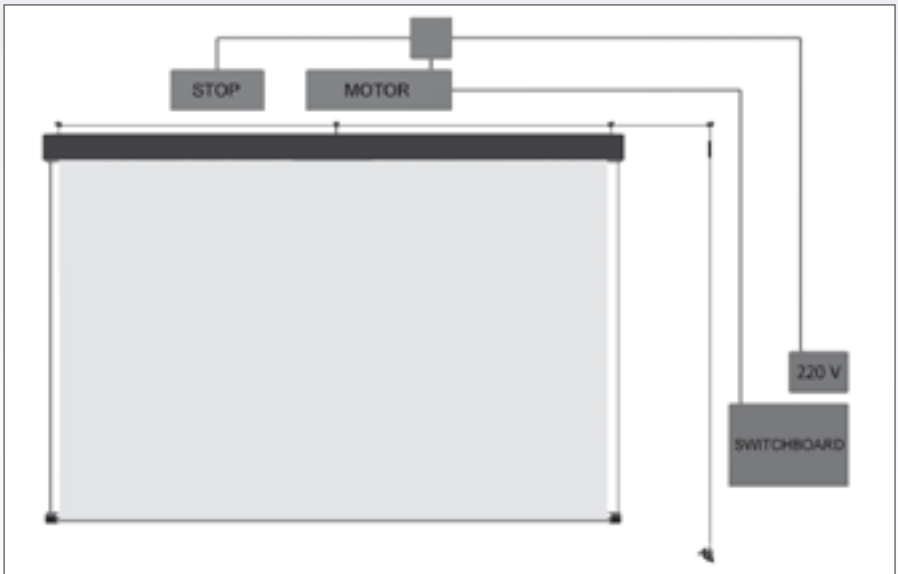

The running ends are controlled by the switchboard.

Fashion

The extremely modern and fashionable aesthetic embraces the highest care for details.

The rounded profile is enriched by the black dull varnish or the special velvety finishing.

The projected image is perfectly absorbed by the black frame. Rounded nylon anlges get the same treatment to be completely unnoticeable from the structure.

Easy and quick to fix the fabric on the frame, invisible wall mounting thanks to the special brackets, this screen can be aswell hanged on the ceiling by the supplied iron hooks.

Wide range of available surfaces: front or rear, grey-high contrast and high light suitable to day-light applications.

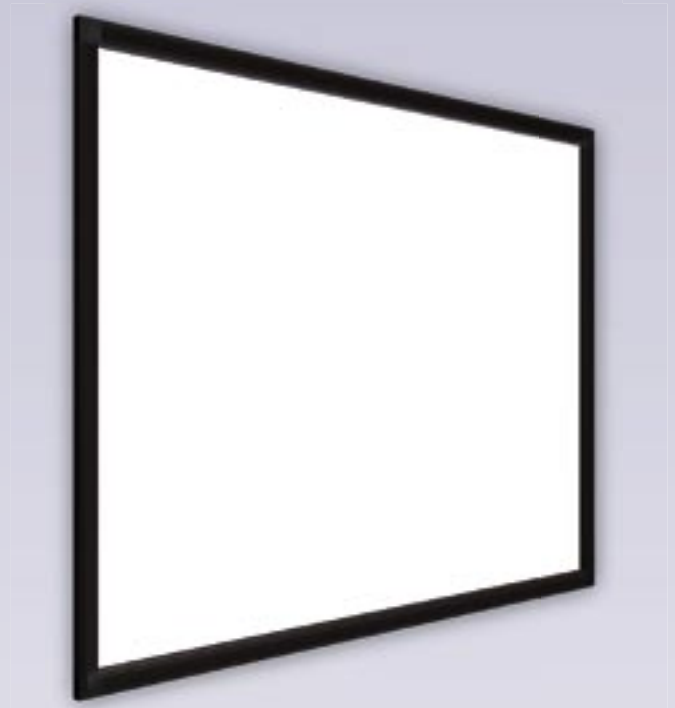

A 3-point fastening system is used to secure the screen to the back wall.



View of how the fabric and corners are attached to the frame.

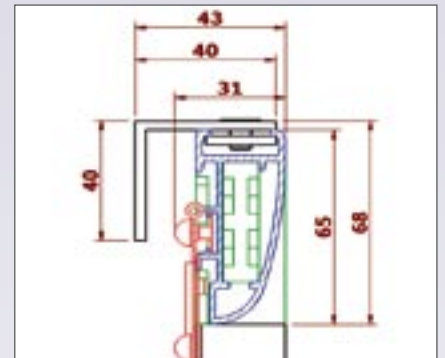

Dimensions of the lateral section of the screen.

Fashion/Fashion Retrolight size-chart

Mod	4:3		16:9		encumbrance 4:3		encumbrance 16:9	
	B x H (cm)	D	B x H (cm)	D	B x H (cm)	B x H (cm)	B x H (cm)	
122	122 x 91	060"	122 x 69	055"	135 x 104	135 x 82		
152	152 x 114	075"	152 x 86	069"	165 x 127	165 x 99		
169	169 x 95	076"	169 x 95	076"	182 x 108	182 x 113		
183	183 x 137	090"	183 x 103	082"	196 x 150	196 x 116		
203	203 x 152	100"	203 x 114	091"	216 x 165	216 x 127		
213	213 x 160	105"	213 x 120	096"	226 x 173	226 x 133		
225	225 x 169	110"	225 x 126	101"	238 x 182	238 x 139		
250	250 x 188	123"	250 x 140	113"	263 x 201	263 x 153		
270	270 x 203	133"	270 x 152	123"	283 x 216	283 x 165		
300	300 x 225	148"	300 x 169	136"	313 x 238	313 x 182		
334	334 x 250	164"	334 x 188	151"	347 x 263	347 x 201		
350	350 x 263	172"	350 x 197	158"	363 x 276	363 x 210		
400	400 x 300	197"	400 x 225	181"	413 x 313	413 x 238		

Features

- fashionable profile
- wide range of fabrics
- velvety frame on request
- optional stands for floor application

Available surfaces

- diamond
- microperforated
- grey high-contrast
- ambra
- high light on request

Fashion Retrolight



Fashion Retrolight is the revolution of the cinema at home! The screen provides a new viewing experience thanks to the backlighting that enlightens the frame laterally. Its controller device operates by switching the leds on first to the maximum intensity for a few minutes then by slowing the brightness down while projecting. In the automatic mode, when VPR is switched off, the LED brightness comes back into its 100% emphasising the outline of the black aluminium screen profile. It has been adjusted by an infrared remote control. The interface unit fits all domotic systems and is available in four colours or the latest version with strips rgb in 16,8 million colours.



The smartly rounded frame profile.



Available with white, blue, amber or red light. In the RGB version, the screen can take on all the colours of the rainbow. From lilac to sky blue, passing through yellowish, according to the mood you are in.

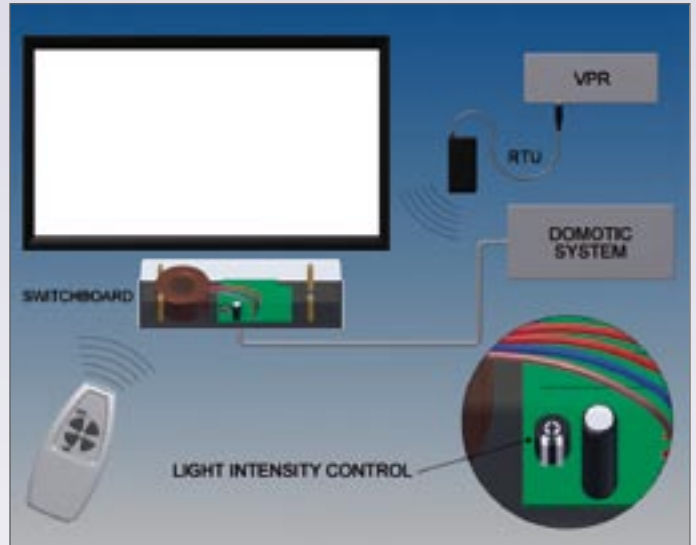

The electronic control unit, the remote control, and the Radio Transmitter Unit (RTU) are supplied in the package.

Features

- velvety profile
- wide choice of chromatic illuminating leds
- adjustable reflex
- light intensity sincronized to VPR turning on
- black aluminium frame on request
- customized sizes on request

Available surfaces

- diamond
- microperforated
- grey high-contrast
- ambra
- high light on request

Fashion Velvet Wide

The real movie experience.

Enjoy greatly the home cinema with the Wide aspect ratio: 2,35:1. Fashion Wide allows you to emulate the original motion picture format and to feel the cinema experience comfortably at home. Special attention to the distinguishing details of the velvety finish that smoothly covers the black aluminium frame. Microperforated foil is now available and allows you to hide your speakers behind the screen and get your living room in trim. Now you can relax and entertain yourself with a greater visual impact!

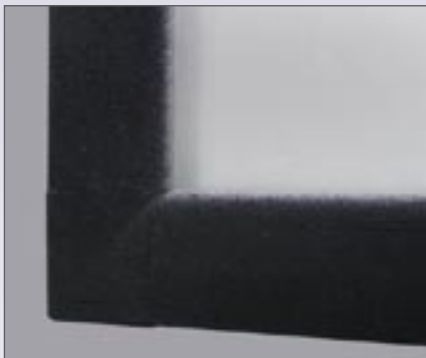
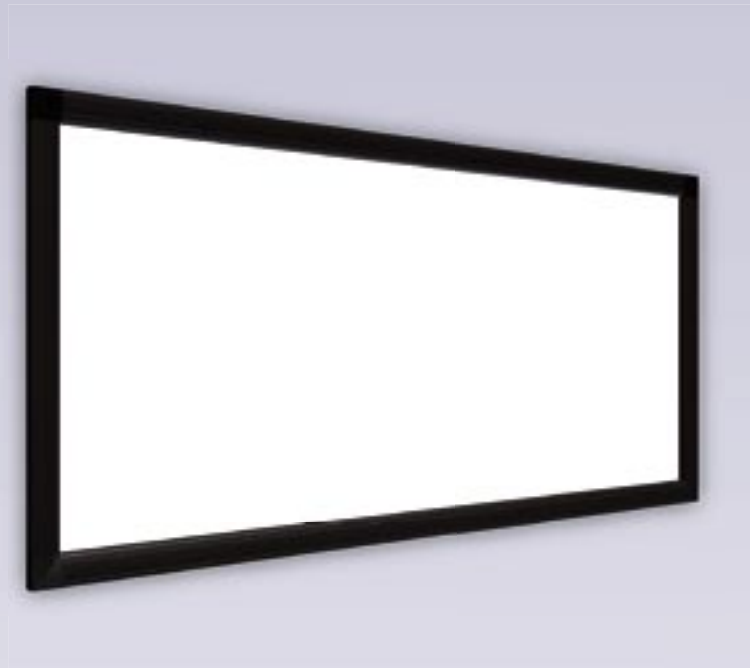

Close-up of the corner, which is perfectly coated with black velvet.



Illustration of the elegant and efficacious system for attaching the fabric to the frame.

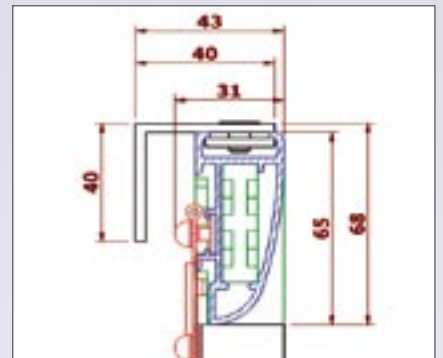

Dimensions of the lateral section of the screen.

Size-chart

Mod					
	B x H (cm)	D	B x H (cm)	KG	
122	122 x 52	052"	135 x 65	10	
152	152 x 65	065"	165 x 78	10,5	
169	169 x 72	072"	182 x 85	11	
183	183 x 78	078"	196 x 91	11,5	
203	203 x 87	087"	216 x 100	12	
213	213 x 91	091"	226 x 104	12,5	
225	225 x 96	096"	238 x 109	13	
250	250 x 107	107"	263 x 120	14	
270	270 x 116	116"	283 x 129	15	
300	300 x 129	129"	313 x 142	16	
334	334 x 143	143"	347 x 156	17	
350	350 x 150	150"	363 x 163	18	
366	366 x 157	157"	379 x 170	19	
400	400 x 171	171"	413 x 184	20	

Features

- anamorphic superior video format
- velvety finishing
- black aluminium profile on request
- seamless fabric
- bevelled edges in a way that conforms to the safety TUV rules

Available surfaces

- diamond
- microperforated
- grey high-contrast
- ambra
- high light on request

Big Frame



Conceived for the large-sized video projection and composed of a black aluminium profile that is bending- and torsion-proof. At the back of the frame structure you find the tracks where sliding bolts are positioned to be hooked to the metallic eyelets of the screen surface. Its functional triple-track system allows you to enlarge or narrow the PVC surface whenever the PVC screen surface expands or reduce because of temperature change. The frame joints are of zinc-coated steel. The screen with a width over 6 meters are equipped with a central bar and adjustable cords that keep perfectly the size. The assembly is easy and notional. Its mounting kit includes 4 wall-mounting brackets.

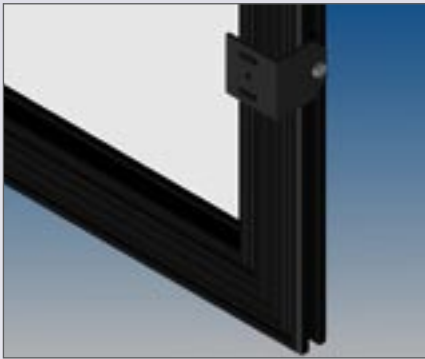

A 4-point fastening system to secure the screen to the wall.

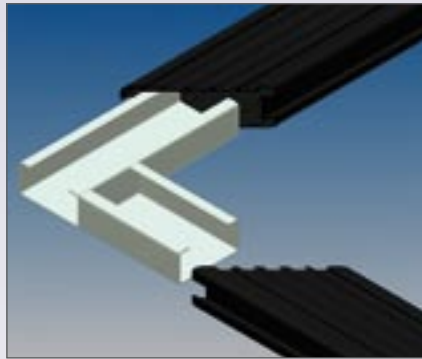

The corners and segment joints are made of zinc-coated sound steel.

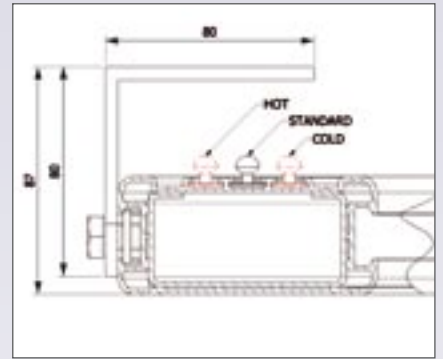

Dimensions of the lateral section of the screen.

Size-chart

Mod	4:3		16:9		encumbrance 4:3		encumbrance 16:9	
	B x H (cm)	D	B x H (cm)	D	B x H (cm)	B x H (cm)	B x H (cm)	
500	500 x 375	246"	500 x 281	226"	520 x 395	520 x 301		
600	600 x 450	295"	600 x 338	271"	620 x 470	620 x 358		
700	700 x 525	344"	700 x 394	316"	720 x 545	720 x 414		
800	800 x 600	394"	800 x 450	361"	820 x 620	820 x 470		
900	900 x 675	443"	900 x 506	406"	920 x 695	920 x 526		
1000	1000 x 750	492"	1000 x 562	452"	1020 x 770	1020 x 682		

Features

- aluminium structure
- PVC surfaces with steel eyelets and reinforced angles
- easy mounting
- anti-bending central bar
- optional T-stands as available accessories up to 600 cm-width

Available surfaces

- diamond
- perforated
- ambra

Multiframe

Multiframe is a system of stackable frame segments, ideal for rental. The segments length are fixed and of 7 sizes, from 25 up to 112 cm width. The smallest sized screen is composed of 8 segments and the largest of 14 segments.

The system is composed of a frame, a screen, and T-stands, all supplied in one-meter carry bag. You can have a second screen size, easily adding 1 screen surface and a couple of segments. You can get 15 different screen sizes in the 4:3, 16:9 and 1:1 format by combining 24 segments of various lengths. The trolley bag with wheels is optional and can carry up to 24 segments and 2 screens. The T-stand are adjustable in its height. The screen can be for front and rear projection. All surfaces are stretchable and strong with reinforced angles; they have a black border with metallic eyelets to get used for service.



The large trolley bag makes for easier transport.

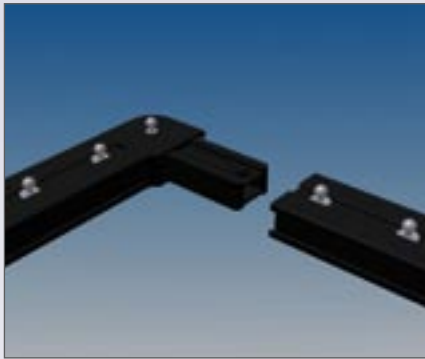

The corner and straight joints are made of high-resistance plastic.



The length of the most frequently used segments ranges from 25 to 99 cm.

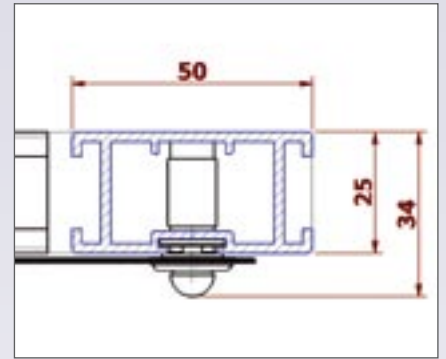

Dimensions of the lateral section of the screen.

Size-chart

Mod	4:3		16:9		1:1		encumbrance 4:3		encumbrance 16:9		encumbrance 1:1	
	B x H (cm)	D	B x H (cm)	D	B x H (cm)	D	B x H (cm)	B x H (cm)	B x H (cm)	B x H (cm)	B x H (cm)	
169	169 x 126	083"	169 x 100	077"	169 x 169	094"	179 x 136	179 x 110	179 x 179			
200	200 x 150	098"	200 x 112	090"	200 x 200	111"	210 x 160	210 x 122	210 x 210			
225	225 x 169	111"	225 x 126	102"	225 x 225	125"	235 x 179	235 x 136	235 x 235			
250	250 x 200	126"	250 x 140	113"	250 x 250	139"	260 x 210	260 x 150	260 x 260			
300	300 x 225	148"	300 x 169	136"	300 x 300	167"	310 x 235	310 x 179	310 x 310			
350	350 x 269	174"	350 x 200	159"			360 x 279	360 x 210				
400	400 x 300	197"	400 x 225	180"			410 x 310	410 x 235				

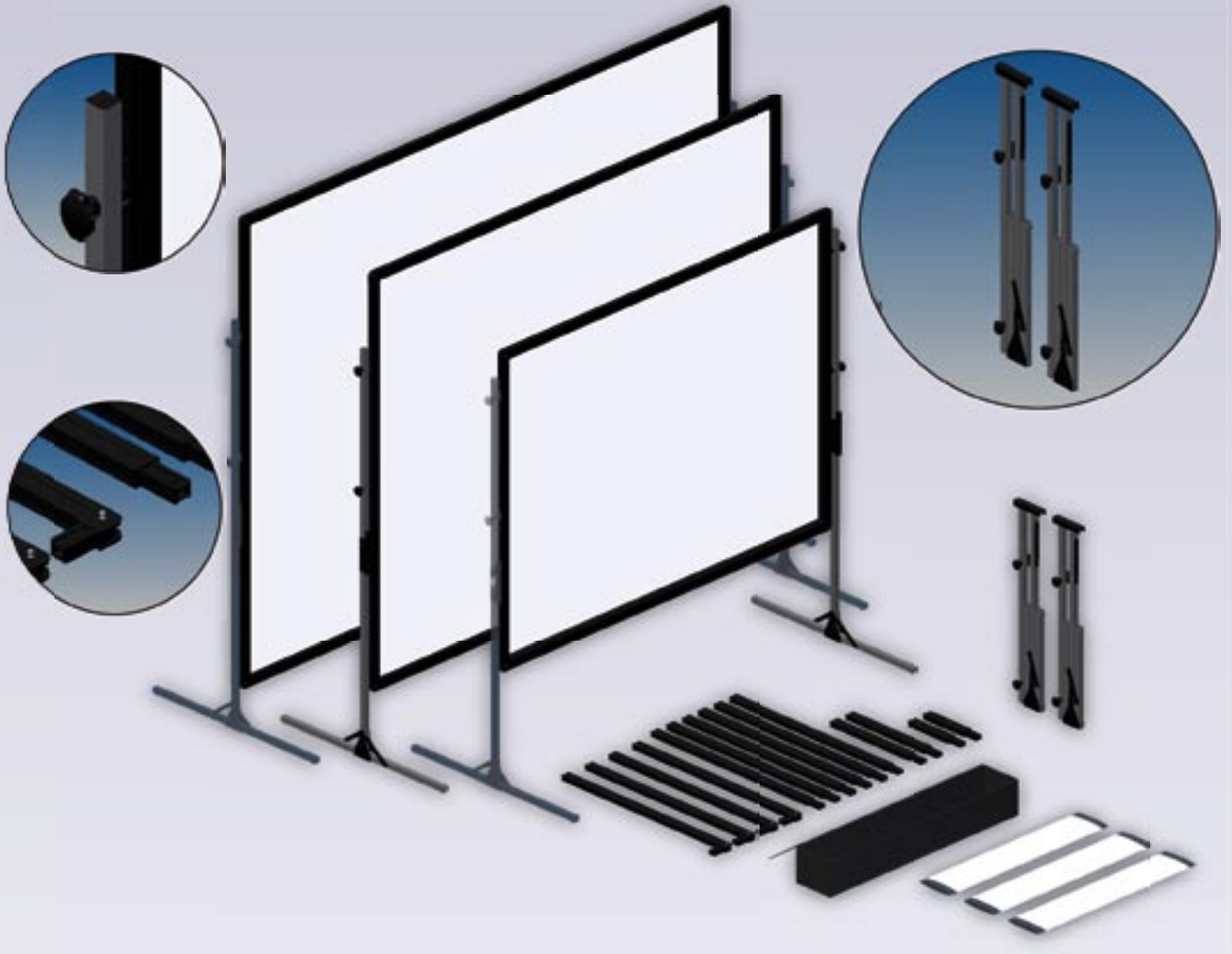

Features

- modular system to get more screens in one carry bag
- quick assembly
- optional carry bag with wheels
- light intensity synchronized to VPR turning on
- stretchable and strong screens

Available surfaces

- diamond
- ambra



The trolley bag holds everything one needs to assemble screens picked from a wide range of different sizes.



New Convention

Finally a portable screen matching stability and elegance! The aluminium base the convenient handle bar make it easy to be carried and used both on the floor and on a mezzanine. The box houses the black bordered cloth, that keeps its flatness when open. New Convention is the ideal manual choice when the environment requires elegance and high level projections.

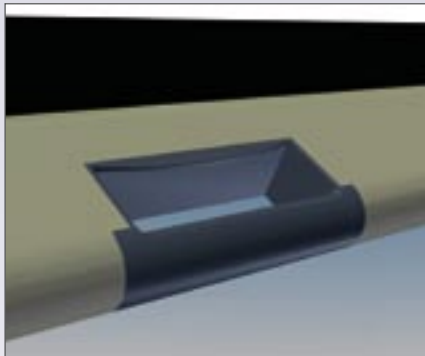

Handle for transport.



The height of the screen fabric can be adjusted with the back rod.



The matt white fabric with a black background shields the picture from backlight.

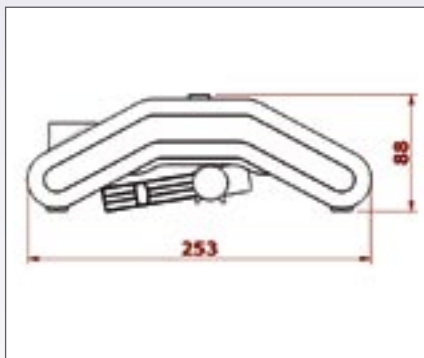

Dimensions of the lateral section of the screen.

Size-chart

Mod	B x H (cm)	D	L (cm)
120	116 x 87	059"	130
160	156 x 117	079"	170
180	176 x 132	089"	190

Features

- extremely easy to install and shelve
- easy to carry
- fashionable design
- black masked

Available surfaces

- matt white

Ecospringroll

Entry level manual spring screen.
 Wide choice of available sizes for a competitive and good quality screen.
 Aluminium box and PVC fireproof B1 certified surface.
 It can be easily installed both on the wall and on the ceiling.
 Automatic stop&go any 13 cm.

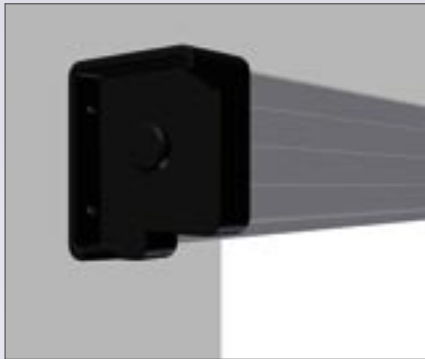
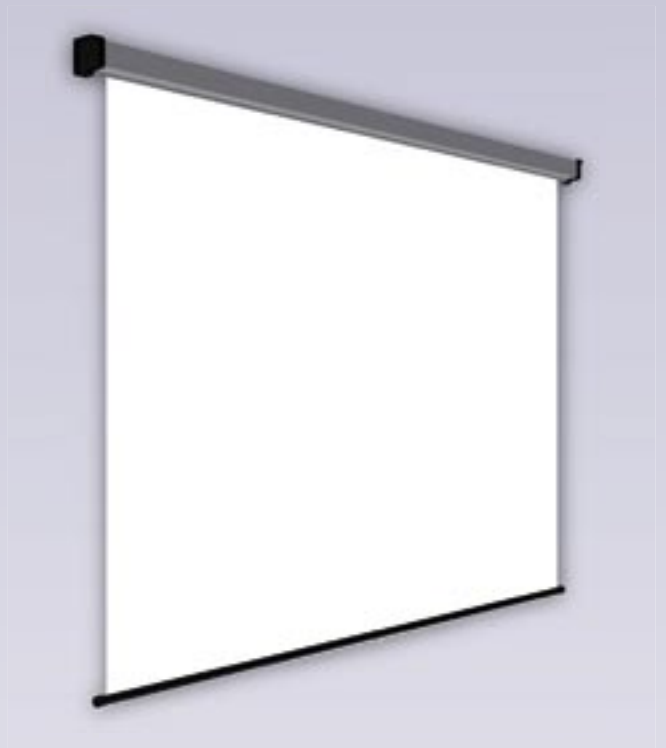

Sides in black nylon with holes for wall/ceiling mounting.

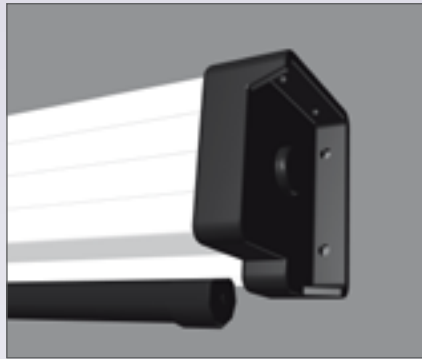

Case in anodized aluminium.

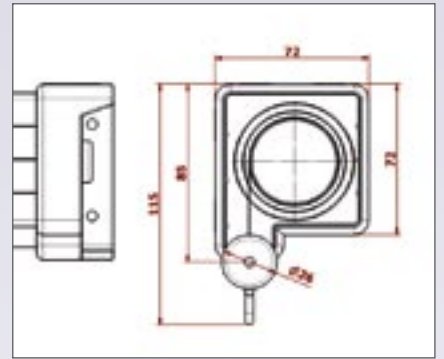

Dimensions of the lateral section of the screen.

Size-chart

Mod	B x H (cm)	L (cm)
125	125 x 125	138
155	155 x 155	168
180	180 x 180	193
200	200 x 200	218
240	240 x 240	258

Features

- anodized aluminium box
- black nylon lateral sides with fixing holes for wall and ceiling
- automatic stop&go any 13 cm
- B1 fireproof certified PVC fabric

Available surfaces

- white ice

Ecotripod

Extremely easy to be used Ecotripod screen enriched ScreenLine's manual range.
 Easy to be carried and small sized it has been having a great success especially on public tenders.
 The keen price make it mostly suitable to slides and recreational projections.

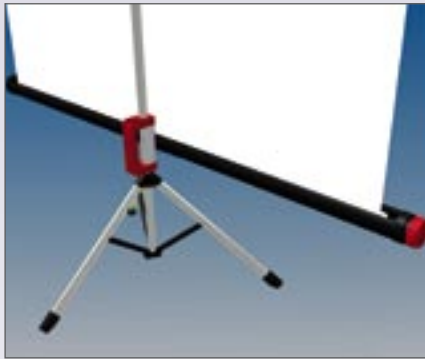

Rear view with unfolded tripod.



The adjustable rod determines the height of the screen fabric.



Once it has been fully rolled up and closed, this screen is easy to carry.

Size-chart

Mod	B x H (cm)	L (cm)
125	125 x 125	138
155	155 x 155	168
180	180 x 180	193
200	200 x 200	213
240	240 x 240	253

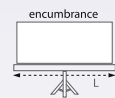

Features

- light shaped painted steel box
- chromium-plated tripod
- manual control of the fabric tensioning
- B1 fireproof certified PVC fabric

Available surfaces

- white ice

Wall Deluxx

Manual wall mounting screen with an elegant aluminium cover and an impressive noiseless device that allows the screen to be stopped with an ease out movement to avoid any screen damage. The device stop&go allows you to shift the screen height every 13 cm. The biggest size, 240 cm-width, is representing the definitive choice for many middle-sized conference rooms where the videoprojection mixes the communication by entertaining you to a T!

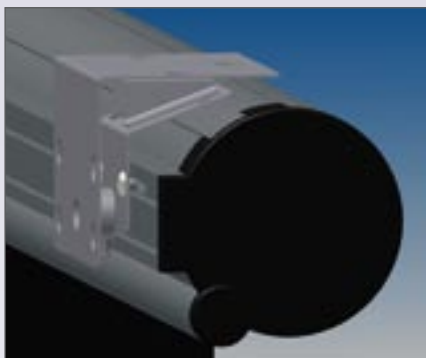

Handy and versatile wall/ceiling mounting system.

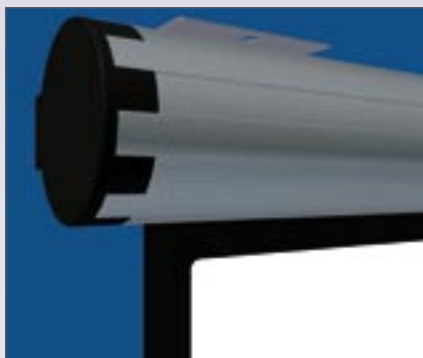

Quality varnish for the matt white screen fabric.

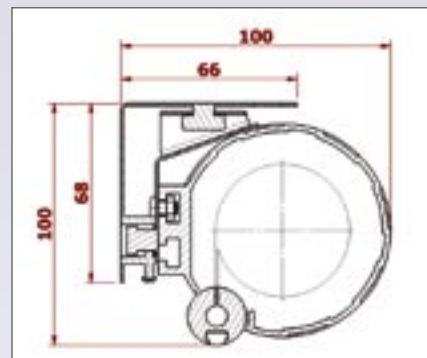

Dimensions of the lateral section of the screen.

Size-chart

Mod	B x H (cm)	D	L (cm)	KG
150	142 x 142	079"	158	10
180	172 x 172	096"	188	12
200	192 x 192	107"	208	14
240	232 x 170	113"	248	17

Features

- high-grade aluminium Silver housing
- Quick & Safe mounting system
- readjusting spring and stopping device every 13 cm

Available surfaces

- matt white



Tripod Deluxx

Tripod screen with a steel cross arm to perfectly flat the surface. The elegant and strong aluminium mechanism together with the fiber-glass black backed surface, allows the screen to be ideal for those who want a screen to be quickly removed after use. Conference rooms, lecture and class rooms are the ideal environment of the product.



The cogwheel greatly stretches the screen fabric.

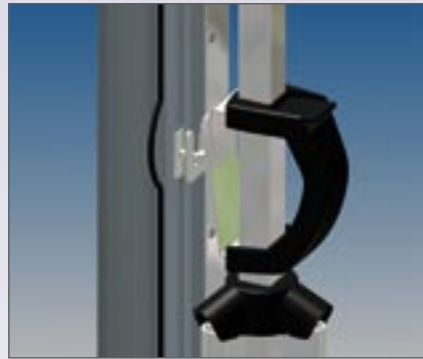

Big handle for easy transport.



The matt white black-grounded fabric shields the picture from backlight.

Size-chart

Mod	Diagram 1		Diagram 2		KG
	B x H (cm)	D	L (cm)	encumbrance	
150	146 x 146	081"	158		12
180	176 x 176	098"	188		14
200	196 x 196	109"	208		17,5
240	236 x 176	116"	248		24

Features

- high-grade aluminium Silver housing
- revolving by 360° at the tripod
- user-friendly
- portable

Available surfaces

- matt white





Grand Cinema Tensioned

Any definition of home cinema must refer to tab-tensioned system which allows the curl-free performance. A tensioning cord and screen combination including a black strip along opposite edges of the screen. The screen is held taut and supported by a special sticking onto an internal tube inside the cover, that allows a perfect screen stretching and flatness. Disposed between the black tensioning cords a concave surface enhances the greater performance and style. By framing the projected image with the black masking you can perceive a greater contrast as the imperfections are absorbed. The black drop allows you to adjust the screen height at the desired level. To make the screen more taut, one need only tighten the nut aside the counterweight. A wide choice of screen surface are available: sound transparent, blacked back foil.

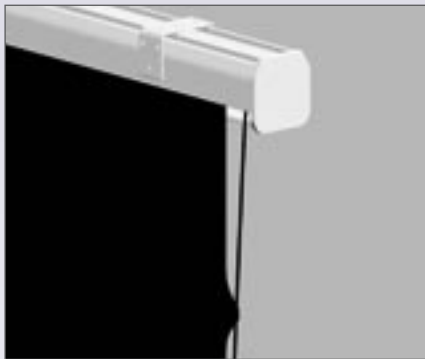

Quick & Safe system: easier mounting on all sides.

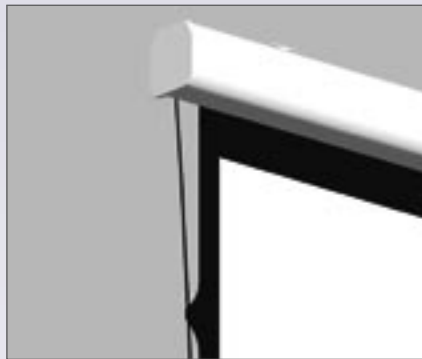

Clean design and impressive tensioning.

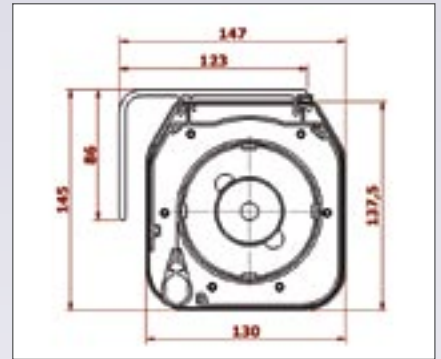

Dimensions of the lateral section of the screen.

Size-chart

Mod	20 cm drop		50 cm drop		L (cm)	KG
	B x H (cm)	D	B x H (cm)	D		
152	152 x 114	075"	152 x 86	069"	182	12
170	170 x 127	084"	170 x 96	077"	200	14
183	183 x 137	090"	183 x 103	083"	213	16
203	203 x 152	100"	203 x 114	092"	233	17
213	213 x 160	105"	213 x 120	096"	243	20
244	244 x 183	120"	244 x 137	110"	274	23
274	274 x 206	135"	274 x 154	124"	304	25
305	305 x 229	150"	305 x 172	138"	335	28

Features

- black masked
- customized sizes on request
- coordinated side plates
- anodized aluminium casing
- tab-tensioning system for a perfect flatness

Available surfaces

- dlp2006
- microperforated
- cine grey
- home vison
- coral on request

Inceiling Screen

When you need me only...
the discreet charm of functionality.
Thought and designed for the ones who need an extreme reliable screen combined with a built-in solution, Inceiling offers the best of ScreenLine technology: flat surfaces and the exclusive Easy-Cut™ mounting system. When not in use it is completely hidden in your room's false ceiling.
Thanks to the Easy-Cut™ system it will be pretty easy to install your screen: the stencil shape gives the exact dimensions of the hole necessary to the installation.

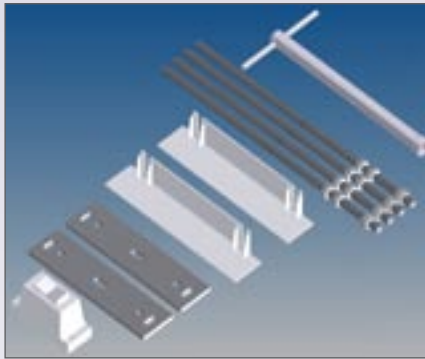
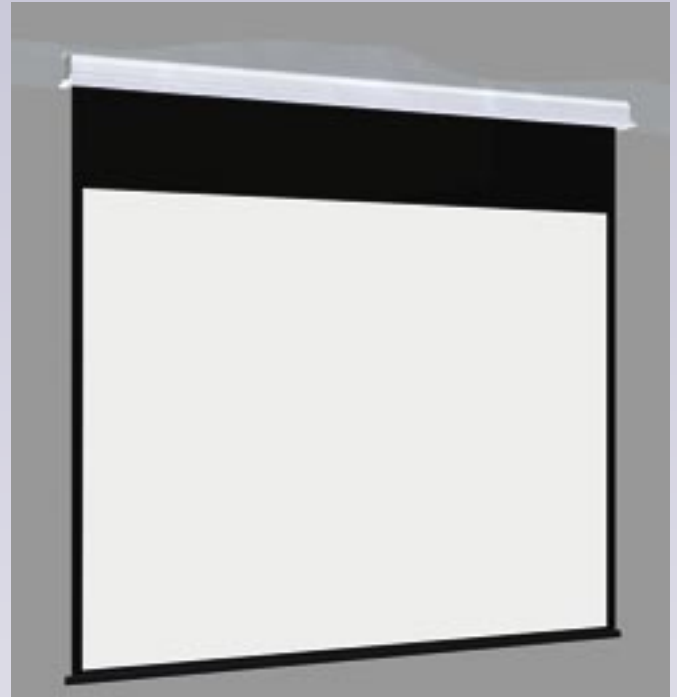

Each box contains everything needed to install the screen.

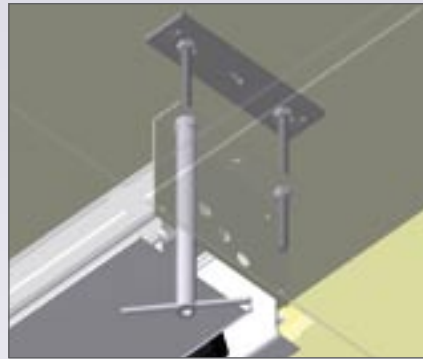

With the help of socket wrenches, the underside can be brought level with the suspended ceiling.

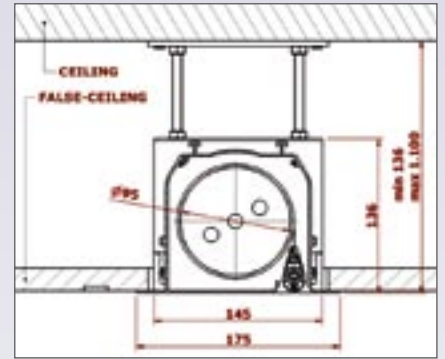

Easy-Cut system: a tape strip surrounds the shape one needs to cut in the suspended ceiling.

Size-chart

Mod	4:3		20 cm drop		50 cm drop		encumbrance	KG	STENCIL SHAPE (cm)
	B x H (cm)	D	B x H (cm)	D	B x H (cm)	D			
160	160 x 120	079"	150 x 112	074"	150 x 84	068"	175,5 x 17,5	13	171,5 x 15
180	180 x 135	088"	170 x 127	084"	170 x 95	077"	195,5 x 17,5	15	191,5 x 15
200	200 x 150	098"	190 x 142	093"	190 x 106	086"	215,5 x 17,5	17,5	211,5 x 15
225	225 x 168	111"	215 x 161	106"	215 x 120	097"	240,5 x 17,5	21	236,5 x 15
250	250 x 190	124"	240 x 180	118"	240 x 135	108"	265,5 x 17,5	24	261,5 x 15
300	300 x 225	148"	290 x 217	143"	290 x 163	131"	315,5 x 17,5	27	311,5 x 15
335	335 x 251	165"	325 x 244	160"	325 x 183	147"	350,5 x 17,5	28,5	346,5 x 15
350	350 x 263	172"	340 x 255	167"	340 x 191	154"	365,5 x 17,5	30	361,5 x 15
400	400 x 300	197"	390 x 293	192"	390 x 220	179"	415,5 x 17,5	34	411,5 x 15

Features

- total concealing
- Easy-Cut™ mounting system
- silent & reliable motors
- remote control available on request
- adjustable fixing bars (up to 95 cm)
- extremely flat surfaces

Available surfaces

- white ice
- home vision
- dlp2006
- matt vision
- coral

Inceiling Tensioned

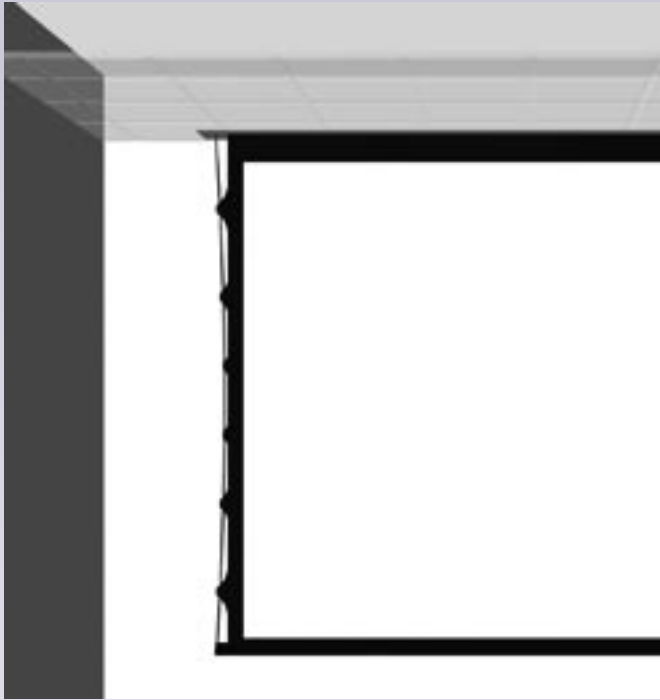

Inspire yourself to the latest screen technology!
 The built-in-range system superbly matches with the technical features of the tab tensioned curl-free surface.
 A new model with the hidden screen case into the false ceiling as the screen disappears when completely rolled up: a great visual impact!
 Easy-Cut™ system allows you to a troubleless mounting.

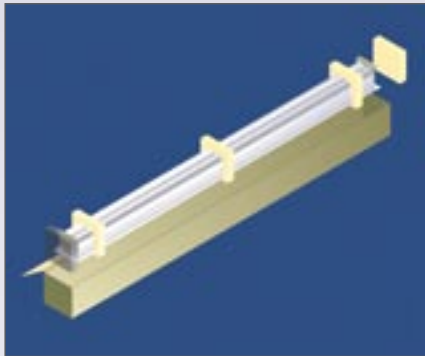

A sound and orderly package safely protects the screen.

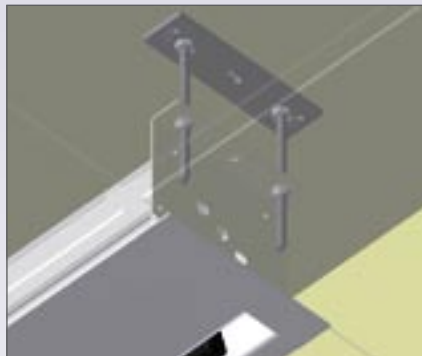

Thanks to the lateral catch, any imperfection in the cut of the suspended ceiling becomes invisible.

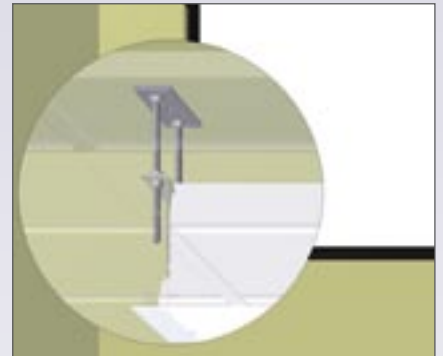

Such screens can be mounted where a one-meter clearance between ceiling and suspended ceiling is available.

Size-chart

Mod	20 cm drop		50 cm drop		encumbrance L	KG	STENCIL SHAPE (cm)
	B x H (cm)	D	B x H (cm)	D			
152	152 x 114	075"	152 x 86	069"	185 x 17,5	13	181 x 15
170	170 x 127	08"	170 x 96	077"	203 x 17,5	15	199 x 15
183	183 x 137	090"	183 x 103	083"	216 x 17,5	17	212 x 15
203	203 x 152	100"	203 x 114	092"	236 x 17,5	18	232 x 15
213	213 x 160	105"	213 x 120	096"	246 x 17,5	21	242 x 15
244	244 x 183	120"	244 x 137	110"	277 x 17,5	24,5	273 x 15
274	274 x 206	135"	274 x 154	124"	307 x 17,5	26,5	303 x 15
305	305 x 229	150"	305 x 172	138"	338 x 17,5	29,5	334 x 15

Features

- total concealing
- Easy-Cut™ mounting system
- silent & reliable motors
- remote control available on request
- adjustable fixing bars (up to 95 cm)
- tab-tensioned

Available surfaces

- dlp2006
- microperforated
- cine grey
- home vision on request

Brilliant

Among top quality screens dedicated to home theatre Brilliant distinguishes for the perfect flat seamless surface with black back. The thickness of the fabric together with unique fabric structure avoids any possible curl problem on the surface. The black dull masking absorb completely the projected image. The compact case is enriched by the 2 white coordinated side plates.

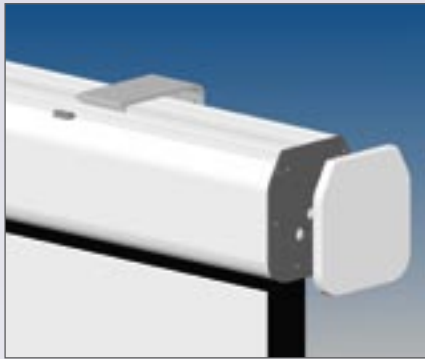
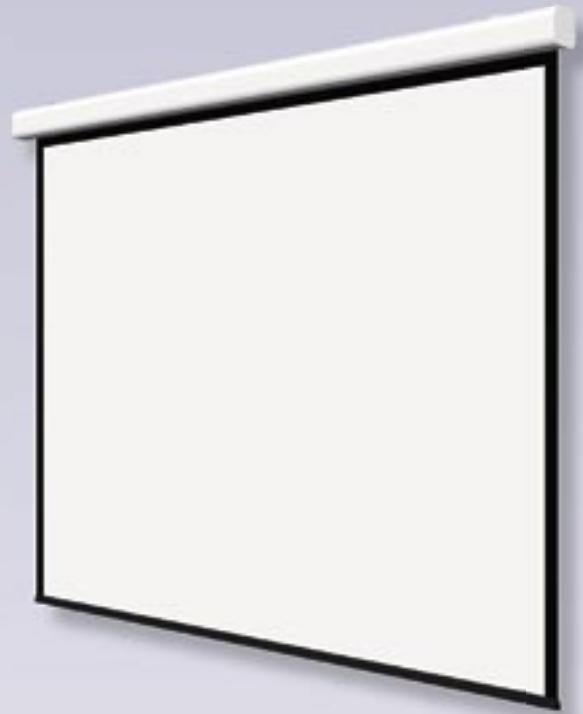

The screen is fastened and secured with an elastic snap.

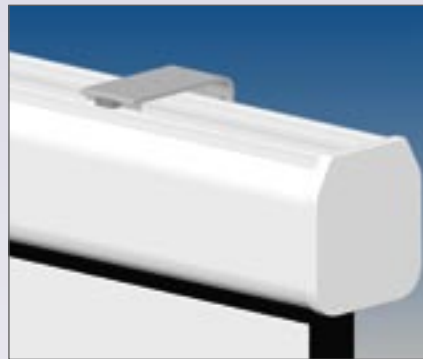

Quick & Safe system. Side covers in matching colours.

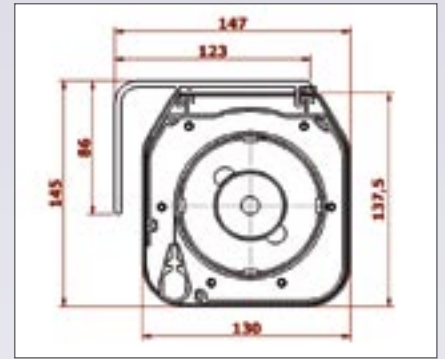

Dimensions of the lateral section of the screen.

Size-chart

Mod	4:3		20 cm drop 4:3		50 cm drop 16:9		L (cm)	KG
	B x H (cm)	D	B x H (cm)	D	B x H (cm)	D		
122	122 x 91	060"	122 x 91	060"	122 x 69	055"	142	10
152	152 x 114	075"	152 x 114	075"	152 x 86	069"	172	12
170	170 x 127	084"	170 x 127	084"	170 x 96	077"	190	14
183	183 x 137	090"	183 x 137	090"	183 x 103	083"	203	16
203	203 x 152	100"	203 x 152	100"	203 x 114	092"	223	17
213	213 x 160	105"	213 x 160	105"	213 x 120	096"	233	20
244	244 x 183	120"	244 x 183	120"	244 x 137	110"	264	23
274	274 x 206	135"	274 x 206	135"	274 x 154	124"	294	25
305	305 x 229	150"	305 x 229	150"	305 x 172	138"	325	28

Features

- high thickness fabric
- exceptional flatness
- essential layout
- new silent motors

Available surfaces

- dlp2006
- cine grey
- microperforated
- matt vision on request

Art Screen

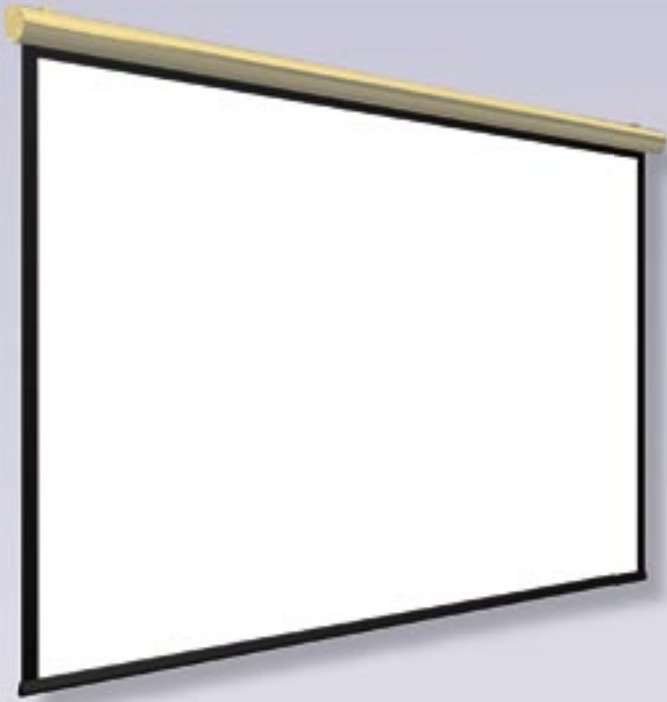

The model is addressed to both home cinema and professional use. The stylish compact case is ideal for any applications where a fashionable and light cover is requested.

A minimal profile allows the screen to be up-to-date with optionally colourable: three different paintings are available, cherry-red, silk-gold and midnight-blue.

The standard format is 16:9.

The screen has a great performance at an exceptional price!

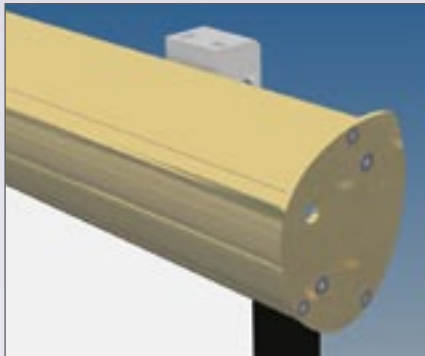

Extremely light and pleasant to the eye.

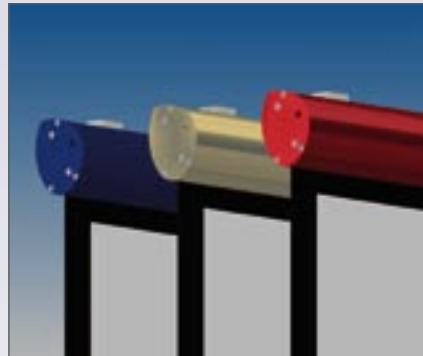

Bright colours for lively and modern settings.

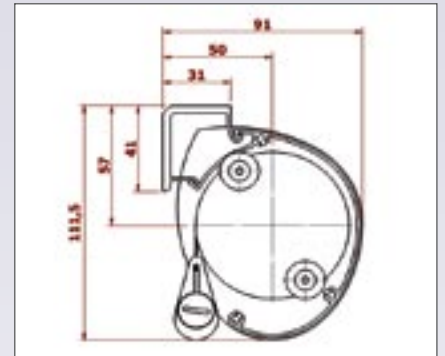

Dimensions of the lateral section of the screen.

Size-chart

Mod	20 cm drop		50 cm drop		L (cm)	KG
	B x H (cm)	D	B x H (cm)	D		
180	170 x 127	084"	170 x 96	077"	188	10
210	200 x 150	098"	200 x 112	090"	218	12
250	240 x 180	118"	240 x 135	108"	258	14

Features

- stylish and compact cover profile
- brassy optional cover colours
- Quick & Safe assembly
- customised sizes on request

Available surfaces

- home vision
- white ice on request

Copernico

A unique screen made to be 4.

The model enhances electronic, aesthetic and optical aspects to get a top level product with excellent performances thanks to a two-motor accurate and precise device. The advanced black-inc digitally printed masking gives the screen a distinctive feature. Copernico gets now bigger sizes with the new 140" and 150" models.

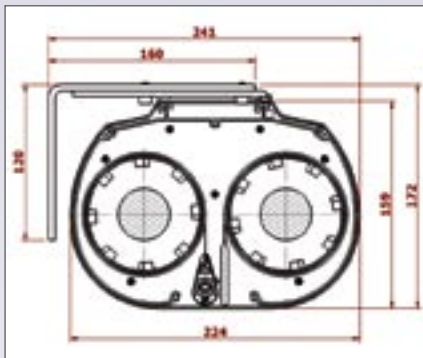

The brackets are mounted on the back wall, on the ceiling and at the front.

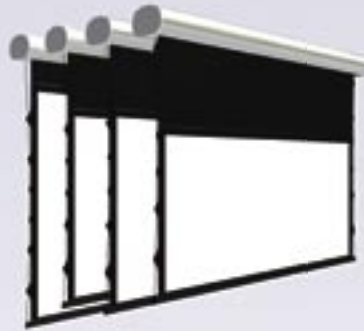

Four sizes, each finely modifiable according to the position of the projector.

4:3 or
1.33:1.00
NTSC Video

1:85:1.00
WideScreen

16:9 or 1.78:1.00
HDTV

2.35:1.00
CinemaScope

Size-chart

Mod	4:3		16:9		1.85:1		21:9		L (cm)	KG
	B x H (cm)	D	B x H (cm)	D	B x H (cm)	D	B x H (cm)	D		
100	203 x 152	100"	203 x 114	092"	203 x 109	091"	203 x 86	087"	232	40
110	223,5 x 167,5	110"	223,5 x 125,5	101"	223,5 x 121	100"	223,5 x 95	096"	252	45
120	244 x 183	120"	244 x 137	110"	244 x 132	109"	244 x 104	104"	272	50
130	264 x 199	130"	264 x 149	119"	264 x 143	118"	264 x 112	113"	292	55
140	284,5 x 160	128"	284,5 x 160	128"	284,5 x 154	127"	284,5 x 121,5	122"	312	60
150	305 x 171,5	138"	305 x 171,5	138"	305 x 165	137"	305 x 130	131"	333	65

Features

- dedicated to 4:3 VPR
- tab-tensioned
- double motor with inner encoders
- customizable ratios by remote
- compatible with domotic interfaces
- stylish rounded case with coordinated side plates
- digital inc-printed masking
- seamless fabrics

Available surfaces

- dlp2006

Copernico Inceiling

Copernico's technology hits the built-in range
A cutting-edge solution for those who want a smoothly hidden installation at home. A combined model that matches the complete concealing of the inceiling models with the advanced technology of the 4format encoders and the tab-tensioned fabrics. New sizes 140" and 150".

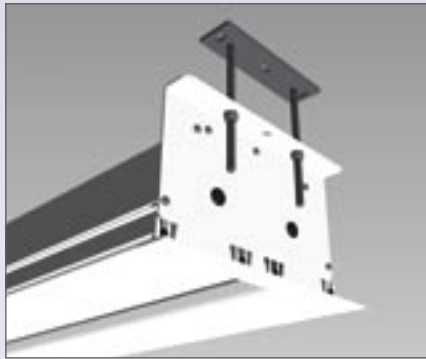

Once the screen is mounted, its structure is perfectly invisible.

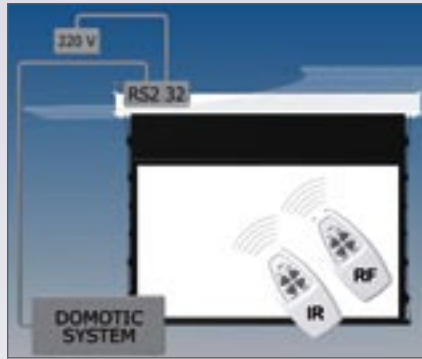

Multi-size screens are supplied with two remote controls and can be connected to any type of house automation system.

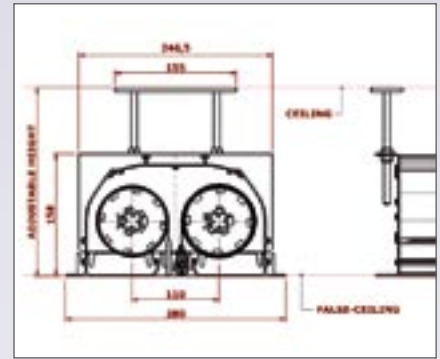

Easy-Cut system: a tape strip surrounds the shape one needs to cut in the suspended ceiling.

Size-chart

Mod	4:3		16:9		1.85:1		21:9		L (cm)	STENCIL SHAPE (cm)	KG
	B x H (cm)	D	B x H (cm)	D	B x H (cm)	D	B x H (cm)	D			
100	203 x 152	100"	203 x 114	092"	203 x 109	091"	203 x 86	087"	235	232 x 25	40
110	223,5 x 167,5	110"	223,5 x 125,5	101"	223,5 x 121	100"	223,5 x 95	096"	255,5	252,5 x 25	45
120	244 x 183	120"	244 x 137	110"	244 x 132	109"	244 x 104	104"	276	273 x 25	50
130	264 x 199	130"	264 x 149	119"	264 x 143	118"	264 x 112	113"	296	293 x 25	55
140	284,5 x 160	128"	284,5 x 160	128"	284,5 x 154	127"	284,5 x 121,5	122"	316,5	313,5 x 25	60
150	305 x 171,5	138"	305 x 171,5	138"	305 x 165	137"	305 x 130	131"	337	334 x 25	65

Features

- dedicated to 4:3 VPR
- built-in screen
- tab-tensioned
- customized ratios by remote
- 2 transmitters included
- compatible with domotic interfaces
- Quick & Safe mounting system

Available surfaces

- dlp2006

Keplero

Enjoy the expertise of home cinema
 Four variable aspect ratios can be obtained thanks to a double dull screen, created to be suitable for 16:9 native VPR it has been enlarging the family of 4format series. It is an electric 2-motor screen: the completely opened 2nd screen shows the 4:3 ratio with a unique digitally printed black frame that superbly suits the projected image!
 Keplero has seamless flat surface and tab-tensioning as standard features.

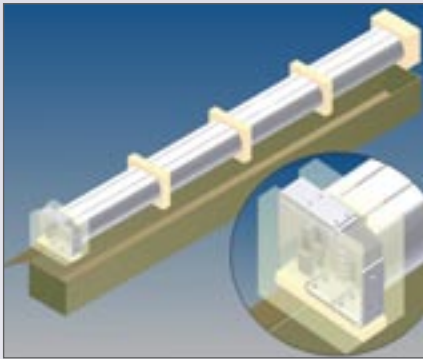

A sound packaging guarantees top protection during transport.

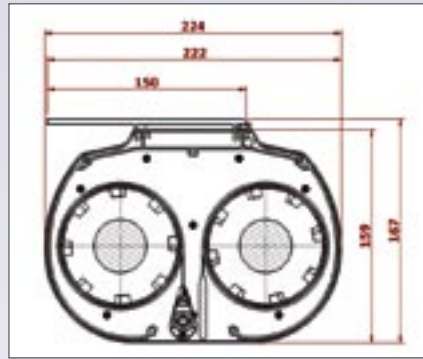

The brackets are mounted on the back wall, on the ceiling and at the front.

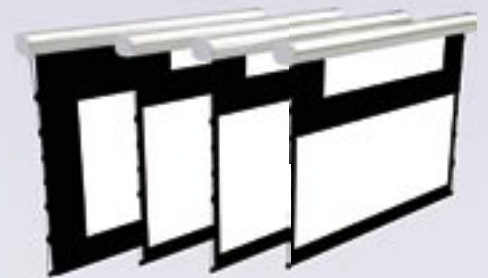

The viewing area can be increased or lowered till 60 cm.

Size-chart

Mod	4:3		16:9		1.85:1		21:9		L (cm)	KG
	B x H (cm)	D	B x H (cm)	D	B x H (cm)	D	B x H (cm)	D		
092	152 x 114	075	203 x 114	092	203 x 110	091	203 x 86,5	087	232	40
101	167,5 x 125,5	082	223,5 x 125,5	101	223,5 x 121	100	223,5 x 95	096	252	45
111	183 x 137	090	244 x 137	111	244 x 134	110	244 x 104	104	272	50
119	198 x 148,5	097	264 x 148,5	119	264 x 143	118	264 x 112,5	113	292	55
128	213,5 x 160	105	284,5 x 160	128	284,5 x 154	127	284,5 x 121	122	312	60
138	229 x 171,5	113	315 x 171,5	138	305 x 165	137	305 x 130	131	333	65

Features

- dedicated to 16:9 VPR
- tab-tensioned
- double motor with inner encoders
- customizable ratios by remote
- compatible with domotic interfaces
- stylish rounded case with coordinated side plates
- digital single inc-printed masking on 4:3 ratio
- seamless fabrics

Available surfaces

- dlp2006

Keplero Inceiling

The ultimate frontier on home theatre.

Top quality model of the entire ScreenLine range, this built-in screen grants the most advanced characteristic on technical and performing aspects.

Impressive screen dropping and easy installation with a terrific concealing that allows it to get visible whenever needed: the false ceiling mounting of the Keplero model, where nothing is left by chance.

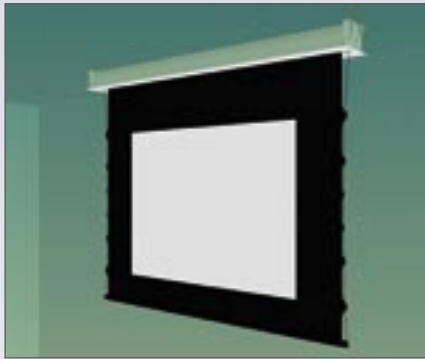

The fore fabric is dedicated to 4:3 ratio.

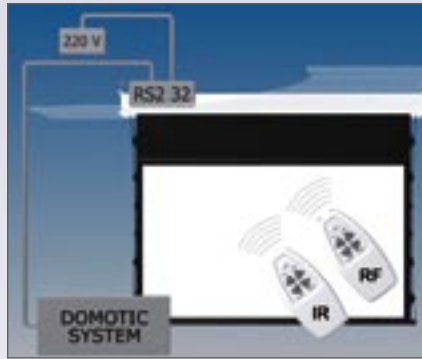

Multi-size screens are supplied with two remote controls and can be connected to any type of house automation system.

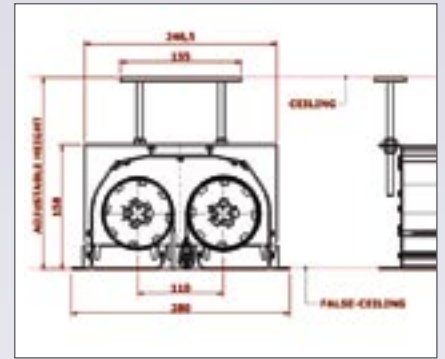

Such screens can be mounted where a one-meter clearance between ceiling and suspended ceiling is available.

Size-chart

Mod	4:3		16:9		1.85:1		21:9		L (cm)	STENCIL SHAPE (cm)	KG
	B x H (cm)	D	B x H (cm)	D	B x H (cm)	D	B x H (cm)	D			
092	152 x 114	075	203 x 114	092	203 x 110	091	203 x 86,5	087	235	232 x 25	40
101	167,5 x 125,5	082	223,5 x 125,5	101	223,5 x 121	100	223,5 x 95	096	255,5	252,5 x 25	45
111	183 x 137	090	244 x 137	111	244 x 134	110	244 x 104	104	276	273 x 25	50
119	198 x 148,5	097	264 x 148,5	119	264 x 143	118	264 x 112,5	113	296	293 x 25	55
128	213,5 x 160	105	284,5 x 160	128	284,5 x 154	127	284,5 x 121	122	316,5	313,5 x 25	60
138	229 x 171,5	113	305 x 171,5	138	305 x 165	137	305 x 130	131	337	334 x 25	65

Features

- dedicated to 16:9 VPR
- built-in screen
- tab-tensioned
- customized ratios by remote
- 2 transmitters included
- compatible with domotic interface
- Quick & Safe mounting system
- digital single inc-printed masking on 4:3 ratio

Available surfaces

- dlp2006

Accessories

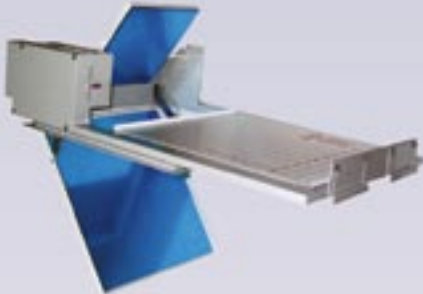

MIRROR HOME CINEMA

An active optic set to be installed in those places where the projection screen and the ceiling are on the same plane or with a difference of 0-12 cm, without causing the trapeze effect on the image. Excellent to be combined with the In-ceiling screen, to get a perfect hidden installation.



VIDEO LIFT

Very tough video projector concealment system. Ideal for overcoming large architectural obstacles in ceilings and to conserve the aesthetics in meeting rooms and homes. Excellent anti-theft system. Compatible with any type of VPR.



ADJUSTABLE CEILING BRACKET FOR VPR

Universal size ceiling-bracket to fix any video-projector model. Easy to be installed, thanks to the small encumbrance, it is the perfect solution to fix any kind VPR (up to 15kg weight) on the ceiling, harmonizing with your home setting.



SPACER BRACKETS 40-60

Allow to insert a space of 40 to 60 cm between the wall and the screen. The fastener can be slightly rotated, so that you can fix the screen to irregular or leaning walls. Moreover, in case of a lateral installation, you can rotate the brackets so as to turn the screen by up to 5° towards the audience. Recommended for motorized screens (eg. Slim, Mot).

VEGA REMOTE

External receiver remote control, available either Infrared or radiofrequency. It can be applied to the screen after its installation.



TOUCH SCREEN

Smooth design for a mimetic Remote that, thanks to the small encumbrances can be easily set in the wall like a standard electric box (mod. 503). This Accessory is a switchboard with an integrated receiver and touch transmitter, basically designed for domestic use where a fully mimetic remote is requested.

Thanks to the Touch Screen it is possible to eliminate any unsightly external receiver and to simply work on the touch control.



RTU: Radio Transmitter Unit For Video-Projector

Thought and designed to speed up your video projection system the RTU endorses to synchronize your video-projector and screen application.

Extremely easy to install and use, it is made up of a small kit – transmitter receiver & connection cable – that only needs to be connected to a 12v dc output.

Small in encumbrance it permits to use an only remote for both VPR and screen.



Fabrics

FLAT VISION

F.P. – gain 1.2 – 400 micron – H roll 2400 mm

Smoothly soft white fabric of PVC. Very thin superficial engraving and perfect flatness for a clear and bright videoprojection. Soldered when the screen width is over 240cm. The black borders are welded along the image. It is ideal for every size and model thanks to its weightlessness and handiness. The fabric being slightly transparent is not suitable whenever you have light sources behind the screen.

HOME VISION

F.P. – gain 1.2 – 400 micron – H roll 2100 mm

PVC fabric composed of both a white and black foil that allows no transparency through it. High definition in the image thanks to a very thin engraving and an excellent flatness. As the black masking are welded and large screen width can be obtained thanks to the welding of more surfaces. It is the ideal fabric for the screens that avoid any light sources.

Note: Don't use as roller blind! The sun gets the screen burned.

MATT VISION

F.P. – gain 1.1 – 950 micron – H roll 4050 mm

A 1-mm thick double-bedded tissue that perform a great flatness. It cannot be welded. The dimensions and the rigidity of the fabric get it suitable to be used for customised black serigraphic painted masking.

It perfectly suits for screen width from 300x225cm (Brilliant model) up to 600x340cm (Lodovico model).

DLP2006

F.P. – gain 1.0 – 450 micron – H roll 2400 mm

A synthetic fibre double-bedded black backed fabric. It cannot be welded. The gain is slightly lower than the front projection PVC fabric range. The fabric has a flat matted topped surface that get it ideal for the ideal as a home cinema appliance. Black masking is digitally performed and the black colour is obtained by a painting system that allows to include any pictures and logos. Ideal for screen from small up to medium size with or without lateral tab tensioned system. It performs best with powerful up-to-date VPR. The fabric black backing allows the screen to avoid any light source behind it. The biggest size is 3050x1715mm with a maximum black drop of 500mm.

CINE-GREY

F.P. – gain 0.8 – 450 micron – H roll 2400 mm

The high contrast version of DLP2006's fabric.

The reflected brightness is lower while the sighted contrast increases up to 10% in an adequate dark environment. It cannot be welded. The digitally printed masking and the tab tensioning system get it suitable for convenient videoprojection rooms. You reach its best performance by using high brightness and contrast VPR.

CORAL

R.P. – gain 2.8 – 400 micron – H roll 2400 mm

Fabric of PVC for rear projection only. The thickness and the texture get the fabric ideal for electric screens.

The gain is high and the lightness is homogenously spread on the topped surface. The black borders are welded in order to get larger sizes and achieve a perfect flatness too. The mercurial performance gets the fabric a perfect solution for enlightened environments and the combination with powerful VPR will optimize the projection. The viewing angle is over 90° on the whole. As the front projection fabrics, the foil does not welcome any environmental direct light that slashes the contrast.

DIAMOND

F.P. – gain 1.4 – 250 micron – H roll 2100 mm

PVC grey-backed extra-soft fabric, not transparent. It is used for framed screen thanks to extreme elasticità, it can afford any temperature between 5° and 45°C. It can be welded in order to reach very large screen width. It is manufactured with a black rigid border of PVC with or without metallic eyelets. It can be easily folded to be carried, once stretched in the aluminium frame the screen gets the original flatness.

HIGH LIGHT

F.P. – gain 3.0 – 280 micron – H roll 2000 mm

Elastic as the fabric 'Diamond', it offers an extraordinary lightness and a viewing angle of about 90°. It is crucial while the environment is enlightened as conference rooms, public lounges, offices because its high gain gets the screen the best solution. The short viewing angle allows it to be less sensitive to the presence of both lights and windows.

It is transparent and sensitive to any lights behind the screen. It cannot be welded and it can be used for fixed screens only. The biggest width is 200cm.

AMBRA

R.P. – gain 2.5 – 300 micron – H roll 2400 mm

Rear projection thin and soft fabric. The chemical composition allows to get it folded and re-used many times without damaging with any signs on the fabric.

It is exclusively used for the framed screens. It can be welded and allows to get large screen width. Its great brightness gives the image an excellent contrast. The green colour keeps the chromatic balance, oppositely, gets it less sensitive to the environmental light.

MICROPERFORATED

S.T. – gain 1.0 – 400 micron – H roll 1800 mm

Sound transparent Micro perforated thin foil, ideal for being used when speakers are behind the screen. It is of PVC, the black borders are welded around the projection image. The microperforation is absolutely invisible for the audience and it is perfect for home cinema screen. The biggest size is 3000x1715mm. Microperforated gets its best performance while tab tensioned.

GREY HIGH-CONTRAST

F.P. – gain 0.8 – 600 micron – H roll 2100 mm

Protective surface in soft double-layer PVC with black back. Purpose-designed for video projectors with a light output > 1500 ANSI lumens.

The grey high-contrast surface ensures excellent contrast on dark colours. Recommended for rigid frame screens. Can be welded and is remarkably flexible.

PERFORATED

F.P. – gain 1 – 400 micron – H roll 2400 mm

Surface for front projection; sound transparent, ideal for large-sized screens and, in any case, with a base broader than 300 cm. Made out of PVC. Weldable. Can be used for motorized as well as for frame screens provided the loudspeakers are placed behind the screen.

The perforation is completely invisible during projection.

F.P. = front-projection

R.P. = rear-projection

S.T. = sound-transparent

Corporate Profile

ScreenLine started trading in 1985, in the wake of the emerging market for video projectors.

In 1987, it became a partnership and set up its headquarters in Trento. During the first years of activity, marketing was focussed on manufacturers and professional operators on the Italian market, but was soon extended to foreign markets.

In 1993, ScreenLine was turned into a joint-stock company. In response to a demand for quality on the European market, it embarked on a technological growth programme based on the development of new manufacturing solutions and the search for innovative materials.

Research soon translated into new products: ScreenLine released the first Bigmot screens with two motors and a base measure of up to 12 metres. In collaboration with companies operating in the sector, ScreenLine designed innovative PVC welding machines and introduced solutions that are still being used today, even by its competitors. Examples of such solutions are the invisible screen fabric welds and the binding of the screen surface that consists of welded rather than painted black edges.

1996 saw the release of a rigid screen with a metal surface that increased the gain of the video projector tenfold: eXtralight, gain 10, viewing angle 90° x 20°. Thanks to ScreenLine's first patented screen, it became possible to project pictures in open spaces, i.e. even in sunlight: a small revolution in itself.

In 1997, ScreenLine moved to new headquarters and began to increase its presence on foreign markets. Its facilities were upgraded, and its production area was extended from 1400 to 2000 m². Thanks to its non-stop involvement in European trade fairs from 1998 onwards, the share of exported goods rose to 80%.

The late 1990s saw the release of Multiframe, an innovative screen with a modular frame, which is changeable into dozens of different sizes. By letting you carry around in one single bag all you need to mount 2, 3 or 4 frames of different shapes and sizes, Multiframe met the manifold requirements of entertainment professionals and rental company operators.

In 2001, the project OthelloLine was conceived: a line of screens with an alluring design and a graceful profile targeted at the home cinema market. The project was later extended with the addition of a purpose-designed website.

Inceiling Screen, a line of recessed screens that can be conveniently hidden above a suspended ceiling, was originally devised for the home cinema market, but soon became popular among professionals as well.

ScreenLine then developed a technique that made it easier to mount such screens and that cut installation times: the so-called Easy-Cut™ system that has made Inceiling the favourite type of ceiling-recessed screen among installers and customers alike.

2002 was marked by the development of the 4-format: the only multi-size screen featuring motors with built-in encoders. Relying on RF and IR transmitters, control electronics is compatible with home automation systems. The first model was followed by an Inceiling version and by other purpose-designed models for projectors with a 16:9 matrix.

In 2004, ScreenLine was granted the TÜV quality certification for its products and Vision 2000 certification for its production and management processes. Its management was streamlined and made more efficient thanks to the introduction of precise procedures and to greater attention to customers. ScreenLine also launched an integrated e-commerce system that has optimized production times and eliminated

miscommunications.

At the end of 2006, digital varnishing was introduced, a technique that has made it possible to print in black on screen fabric with absolute perfection. Thanks to colour printing, a screen can now be decorated with artistic motifs or personalized with advertisements.

The latest results of the research into LED lighting have led to the development of Fashion Retrolight, a frame screen which sheds light on the back wall and spread pleasant colours in the projection room, thus reducing eye fatigue.

ScreenLine currently features three production sites, operating in Trentino, in the Veneto, and Piedmont, which account for a total of 6 production lines. It boasts important industrial partnerships, it runs joint research projects with a number of public bodies, and it exhibits each year at major Italian, European and Middle Eastern trade fairs.

Thanks to the curiosity our new products always arise, we have been able to operate extensive distribution networks on four continents. The products we put on the market always become standards in the video projection sector, and undergo non-stop improvement and upgrade.

Just by scrolling down the list of items we manufacture, laymen will come across an array of inspiring proposals, professionals will find concrete answers to their problems, and home cinema lovers will discover tempting architectural solutions.

All these items are bursting with passion, and win hearts and souls of those who own and enjoy them. They are quality objects:

the ScreenLine quality

CEO

Bruno Gomasca

Certifications



SCREENLINE.IT

is distributed by



Indicated sizes and specifications of products are indicative. ScreenLine reserves the right to modify them without any prior written notice.
All our screens are tested and M1 fireproof certified.

Graphic project: www.trentagradi.it



www.screenline.it

designed & manufactured by Screenline Srl
via Nazionale 1/n-1/u – 38060 Besenello – TN – Italy
tel +39 0464 830015/03/04
fax +39 0464 830500
info@screenline.it